

# **Experimental Study of Lighting Simulation with Different Diameter of Light Pipes for Office Buildings**

## **ABSTRACT**

Lighting is crucial for creating energy-efficient and visually comfortable office spaces, especially in deep-plan buildings where natural daylight cannot reach. Light pipes, or tubular daylighting devices, are innovative solutions for bringing daylight into such spaces. They improve indoor environmental quality and reduce artificial lighting. This study investigates the impact of varying light pipe diameters on daylight distribution, uniformity, and overall efficiency in office environments. Using advanced simulation tools, models were developed to analyze light levels under different configurations. The findings reveal that larger diameter light pipes allow more daylight penetration, enhancing illumination levels at the center of spaces while diminishing near the periphery. Maximum illuminance of 179 lux was achieved with a 0.50m diameter light pipe, demonstrating its superior performance over smaller diameters. However, larger diameters require more space and higher costs, while smaller ones are less efficient in deep spaces. Uniformity ratios ranged from 0.36 to 0.37, indicating uneven illumination distribution. The study highlights the importance of balancing light pipe diameter with architectural constraints, energy efficiency, and user comfort. These insights provide a basis for designing sustainable office spaces with optimal daylighting strategies, ensuring both energy savings and occupant well-being.

**Keywords:** Daylighting, light pipes, pipes diameter, simulation

## 1. INTRODUCTION

Lighting is essential in creating energy-efficient and visually comfortable office spaces. A passive daylighting strategy known as light pipes or tubular daylighting devices enhances indoor environmental quality and reduces energy consumption (Fernandez et al., 2023). Using reflective materials, these systems allow daylight to filter into interior spaces, reducing the need for artificial lighting during the day. Many factors affect the performance of light pipes, such as their diameter, material reflectivity, and design configuration. In addition to enhancing illuminance in interior spaces, larger diameters can also increase glare or thermal gains, potentially affecting user comfort (Nair et al., 2014). In order to optimize their performance, an in-depth experiment involving lighting simulations is required. A study of this type can assess how changing the diameter of light pipes affects illuminance uniformity, light penetration depth, and overall energy savings in office buildings (Wu et al., 2024). Through experimental simulations, this paper examines the effectiveness of light pipes with various diameters. The study utilizes advanced simulation tools such as EnergyPlus and Radiance to provide insights into how light pipes can be tailored for optimal daylight distribution in office environments while balancing energy efficiency and occupant comfort (Paul, 2019). The first objective was to find out the possible daylighting strategies to improve the daylighting condition in office building where direct sunlight can't reach through opening [18,19]. In order to achieve this objective 10 offices of Dhaka city were investigated to observe the lighting condition for deep spaces of these office buildings. It shows that 25% to 40% of the office spaces are fully and 15% to 20% of the spaces are partly lack of daylight. It also found that the height of floor, ceiling, opening (lintel to seal height) are directly related for inclusion of daylight in office buildings. At the deep spaces, the effect of daylight is extremely low (85%-100%) or no daylight, due to distance or lack of opening. Work without daylight as well as with artificial light for a long time had an inverse health impact to the employees (Lunn et al., 2017). Light

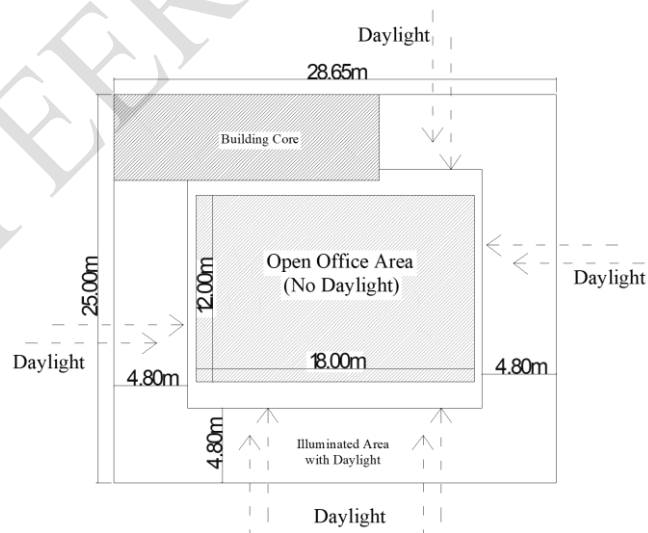
pipes are effective devices used to bring that daylight to the back of deep plan buildings. Light pipes are considered a median to transport light into deep spaces that do not have direct access to the outside [20,21]. Light pipes have a great potential to reduce electricity use in buildings. Daylight usage is a cost-efficient strategy to reduce electric lighting consumption (Ander, 2003).

## 2. METHODOLOGIES OF SIMULATION AND RESULT ANALYSIS

This study describes the basic information required to identify on which simulation could be conducted (Ramos et al., 2010). The 1<sup>st</sup> model (Model 01) used for simulation was only with the internal (open office area) space, there was no opening at the side wall of the model. It is considered that daylight entered from the side window can't reach at this area (Fig. 1). The 2<sup>nd</sup> model (Model 02) used for simulation was equivalent to the whole office space and both-light pipe and side window were considered for different simulations (Fig. 2).



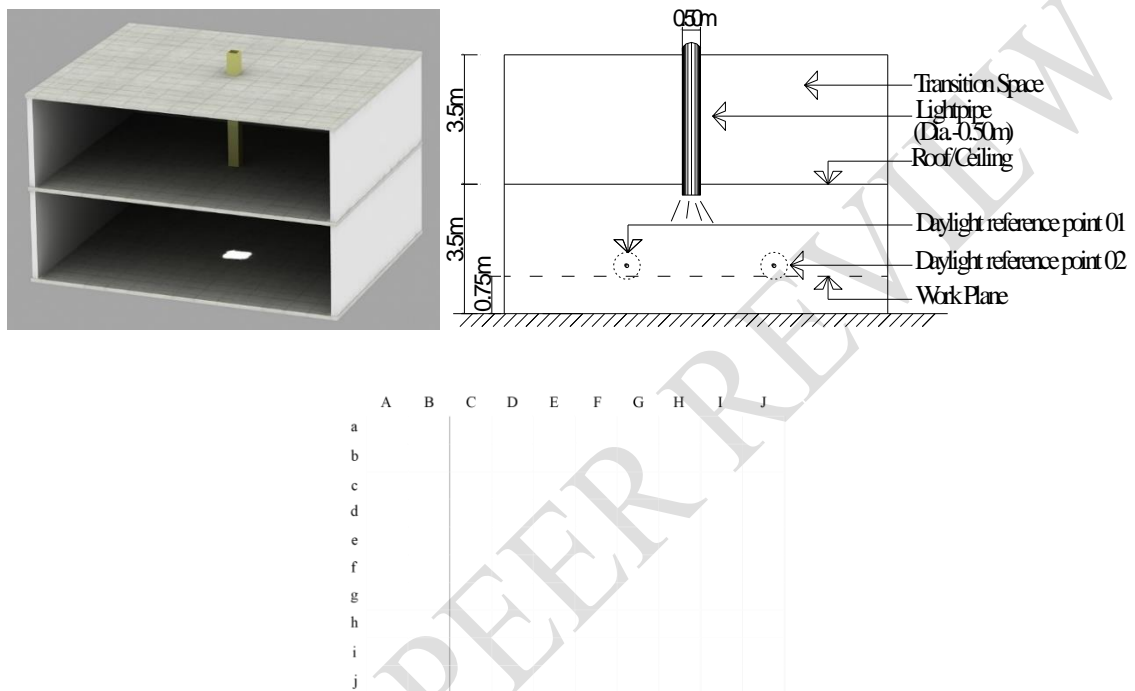
**Figure 1.** Model 01 Plan



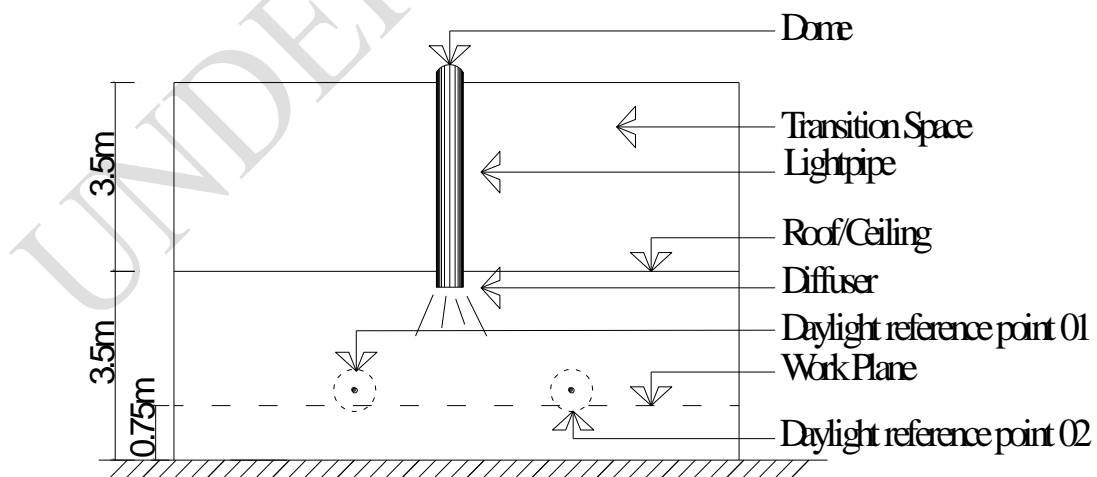
**Figure 2.** Model 02 Plan

In both model there were an illuminance plane with 100 illuminance point at the work plane height (Fig. 3). Daylight entered the interior space was measured at the illuminance point. The simulation time was set for 1.00 am to 12.00 am, but as the office hour starts generally at 9.00am and finished at 6.00pm, only the numeric data of these 10 hours have been considered.

Commonly it was found that maximum light entered at the middle of the day-that is 12.00pm. For this reason, it has been considered the illuminance of the 100 points of 12.00pm for analysis of every case. There were also two (2) daylight reference point named “Daylighting Reference Point 1” and “Daylighting Reference Point 2” (Fig. 4). Daylight was measured at both points also.

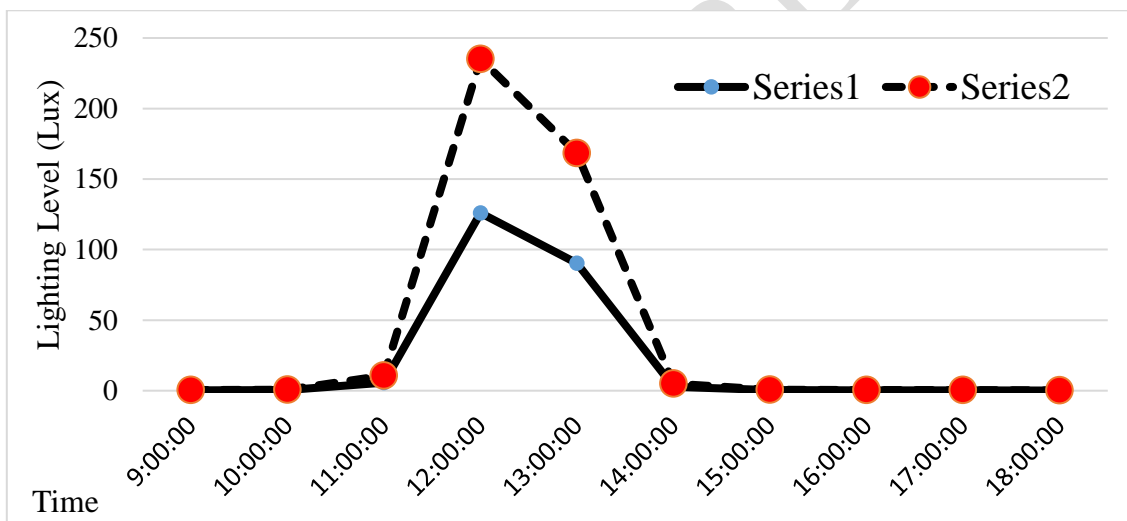


**Figure 3.** Lightpipe- conceptual 3D section and illuminance points (plan)



**Figure 4.** Light pipe and daylight reference points (section)

The simulation results for straight light pipes have presented in four segments by the variation of variables like 1. Light pipe diameter, 2. Light pipe length, 3. Light pipe number (Model 01) and 4. Light pipes with the presence or absent of the side window (Model 02). The simulation results of bended light pipes have presented in three segments by the variation of variables like 5. Light pipe length, 6. Light pipe number (Model 01) and 7. Light pipe with the side window (Model 02). Diameter of Light pipe starts from 0.25m and ends with 0.5m. Length of the light pipe was varied according to floor height such as one floor height (3.5m), two floor height (7.0m), three floor height (10.5m) and four floor height (14.0m). Variation of diameter and length were determined from the available varieties of light pipes in market mentioned in the different published journal about light pipes.



**Figure 5.** Daylighting distribution at illumination plane (Hourly)

Before these, the other outputs e.g. Illuminance at Daylighting Reference Point 1 and 2 are discussed separately because these remain almost same for the same light pipe properties (diameter and length). Daylighting reference point is used for determining the daylighting control sensor location. Fig. 5 show the Illuminance at daylighting reference point 1 and daylighting reference point 2 for one light pipe at different hours of the simulation day. It shows that very small amount of light enters at 9.00 am. It increases continuously till 12.00 pm. At 12.00 pm, it reaches its highest illumination-125.93 lux at point 1 and 109 lux at point 2. At

1.00 pm, it decreases at 90 lux at point 1 and 78 lux at point 2. This is the 2<sup>nd</sup> highest pick point. After 1.00 pm, it starts to decrease and reach at minimum value at 6.00 pm.

### 3. LIGHTING SIMULATION WITH DIFFERENT DIAMETER OF LIGHT

#### PIPES

Lighting simulation with different diameters of light pipes (Table 1) explores how variations in pipe dimensions affect the distribution and intensity of natural or artificial light within a space. Light pipes, designed to transmit light through reflective internal surfaces, are evaluated for their efficiency in delivering illumination. Simulations analyse factors such as light loss, uniformity, and energy savings, providing insights into optimizing pipe diameters for specific architectural applications. Larger diameters generally allow more light transmission but may lead to increased glare, while smaller ones offer focused illumination. These findings are vital for designing energy-efficient lighting systems and enhancing visual comfort in built environments.

**Table 1.** Lighting Simulation with Different Diameter of Light pipe

Case No.	Pipe Diameter	Pipe Length	Number of Pipe	Presence of Window
<b>01(a)</b>	0.25m	3.5m	01	No.
<b>01(b)</b>	0.30m			
<b>01(c)</b>	0.35m			
<b>01(d)</b>	0.40m			
<b>01(e)</b>	0.45m			
<b>01(f)</b>	0.50m			

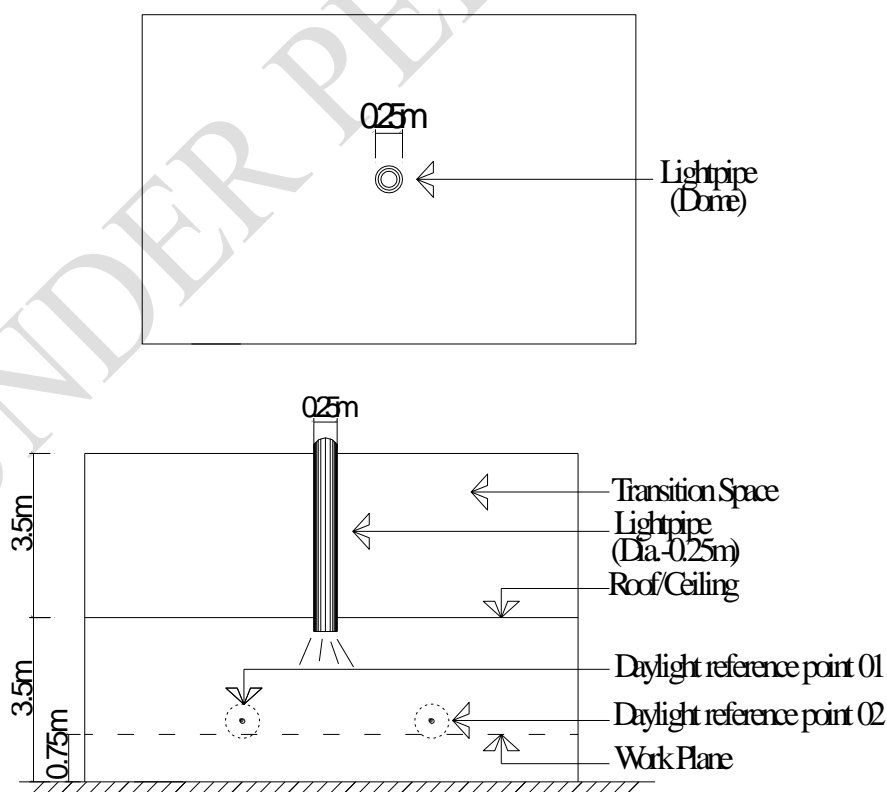
Simulation aspects for case building

Characteristics	Opsonin Building
<b>Type</b>	High Rise Intermediate Floor Designed as Office Building 3 Side open
<b>Date of Establishment</b>	2001-2007
<b>Starting Time</b>	9.00 AM
<b>Closing Time</b>	6.00 PM
<b>Window Type</b>	Sliding (3 Sides) and Fixed (Front)
<b>Window Material</b>	Glass
<b>Type of the Glass</b>	Coloured

<b>Glass Specification</b>	Thickness: 10mm, Conductivity: 0.9 W/m-K, Visible Transmittance: 0.55, Solar Transmittance: 0.775. Density: 160 lb/ft <sup>3</sup>
<b>Floor Height</b>	3.0m
<b>Window Height</b>	2.1m
<b>Sill Height</b>	Below 0.75m
<b>Lintel Height</b>	2.1m
<b>External Shading</b>	No external shading
<b>Internal Blinds</b>	Vertical
<b>Ceiling Height</b>	2.1m
<b>Partition Height</b>	1.2 m
<b>Work Plane Height</b>	0.75 m

### 3.1 CASE 01(A): PIPE DIAMETER 0.25M

This model was created only with the internal (open office area) space, there was no opening at the side wall of the model. There was one (1) light pipe which diameter was 0.25m at the centre of the area with a transition space (height 3.5m-one floor) at the upper part of the model. The Dome of light pipe was set at the top roof (top of the transition space) and the ceiling (bottom of the transition space) contained the Diffuser of the light pipe (Fig. 6).



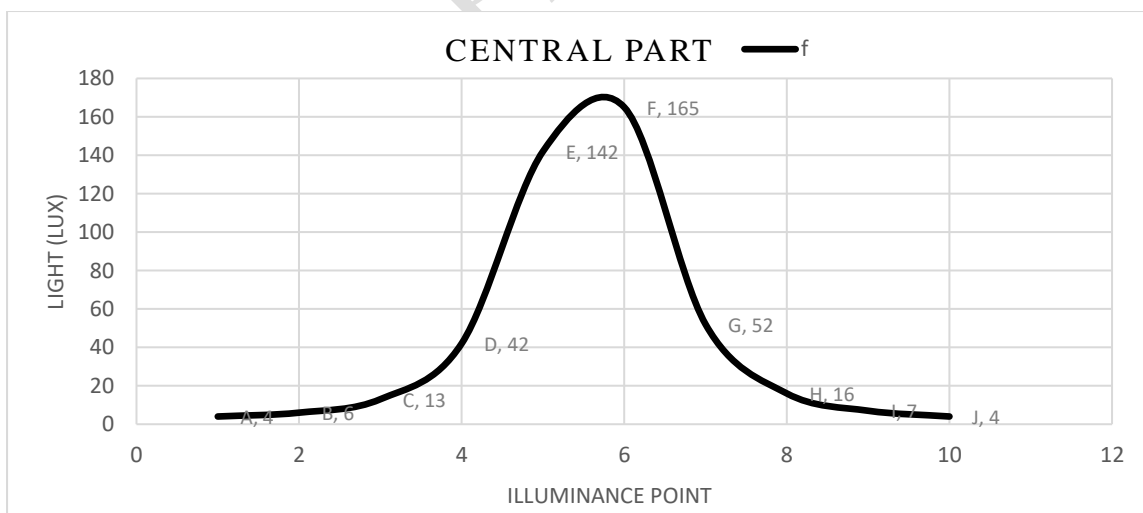
**Figure 6.** Roof plan and section of simulation model 01(a)

**Table 2.** Daylighting distribution at illumination plane for case 01(a)

Point	A	B	C	D	E	F	G	H	I	J
a	3	3	3	3	3	3	3	3	3	3
b	4	4	6	10	15	15	11	7	5	4
c	4	5	8	17	30	32	19	9	5	4
d	4	6	11	28	68	75	33	13	6	4
e	4	6	13	40	130	149	49	15	7	4
f	4	6	13	42	142	165	52	16	7	4
g	4	6	12	31	83	93	38	14	6	4
h	4	5	9	19	38	40	22	10	6	4
i	4	5	7	12	18	18	13	8	5	4
j	3	4	5	7	10	10	8	6	4	3

Note. Colour bar indicates the different intensity of illuminance of work plane

Study shows (Table 2 and Fig. 7) the light level at the 100 points of the illuminance plane of Model 01 at 12.00pm for the light pipe of 0.25m diameter. This light was penetrated by the light pipe installed at the ceiling level. It shows that this daylight only illuminates the centre of the space and constantly decrease at the periphery area. The brightest level of light 165 lux was found at the centre of the space and the light found at the periphery area was very low (less than 50 lux). The average light was only 19.6 lux, and the standard deviation was 31.4 lux. The median was 7 lux. The uniformity ratio below the light at work plane was 0.37.



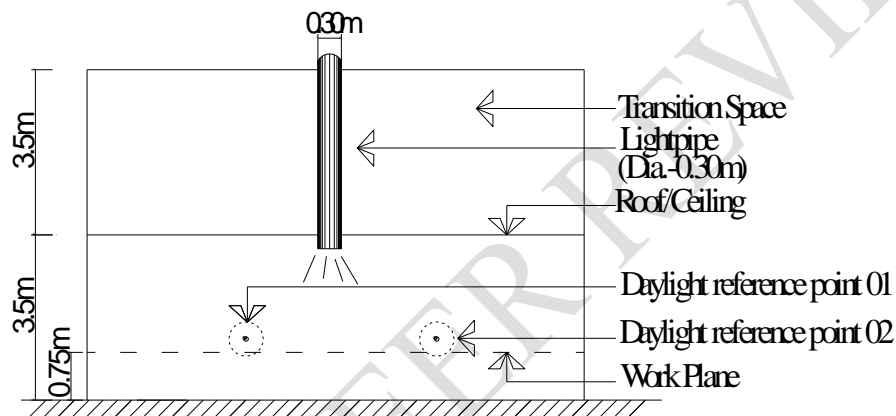
**Figure 7.** Daylighting distribution at central part (f) for case 01(a)

While considering only the illuminance level at the central part-f, it has generated a curve line which indicate that the highest light found at the centre of the space (Fig. 7) and the lighting

was very poor near the edge of the simulated area as installed light pipe with 0.25m diameter can't penetrate more light away from the centre.

### 3.2 CASE 01(B): PIPE DIAMETER 0.30M

In this model, no side walls were opened except for an internal open office area. One light pipe measuring 0.30m was placed in the centre of the space. Over the main office area, a transition space measuring 3.5m in height (representing one floor) was included. A light pipe dome was positioned on the top roof, above the transition space, while a diffuser was installed in the ceiling at the bottom of the transition space (Fig. 8).



**Figure 8.** Section of simulation model 01(b)

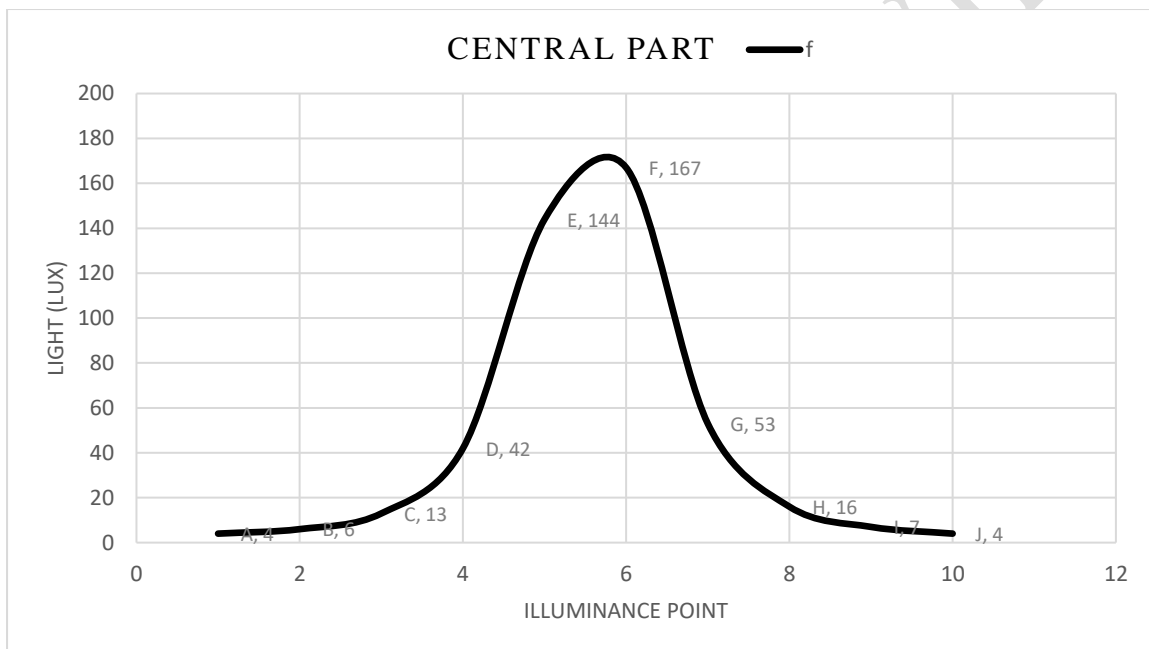
**Table 3.** Daylighting distribution at illumination plane for case 01(b)

Point	A	B	C	D	E	F	G	H	I	J
a	3	3	3	3	3	3	3	3	3	3
b	4	5	7	10	15	16	11	7	5	4
c	4	5	9	17	31	33	19	10	6	4
d	4	6	11	28	69	76	34	13	6	4
e	4	6	13	40	132	151	50	16	7	4
f	4	6	13	42	144	167	53	16	7	4
g	4	6	12	32	84	94	38	14	7	4
h	4	5	9	20	38	41	22	10	6	4
i	4	5	7	12	18	19	13	8	5	4
j	3	4	5	8	10	10	8	6	4	4

Table 3 shows the light level at the 100 points of the illuminance plane of Model 01 at 12.00pm. This light was penetrated by the light pipe installed at the ceiling level. Fig. 8 show that this daylight only illuminates the centre of the space and constantly decrease at the periphery area.

The brightest level of light 167 lux found at the centre of the space and the light found at the periphery area was very low (less than 50 Lux). The average light was only 19.9 and the standard deviation was 31.9 lux. The median was 7 Lux. The median was 7 lux. The uniformity ratio below the light at work plane was 0.36.

While considering only the illuminance level at the central part-f (Table 3), it has generated a curve line which indicate that the highest light found at the centre of the space (Figure 9) and the lighting was very poor near the edge of the simulated area as installed light pipe with 0.30m diameter can't penetrate more light away from the centre.

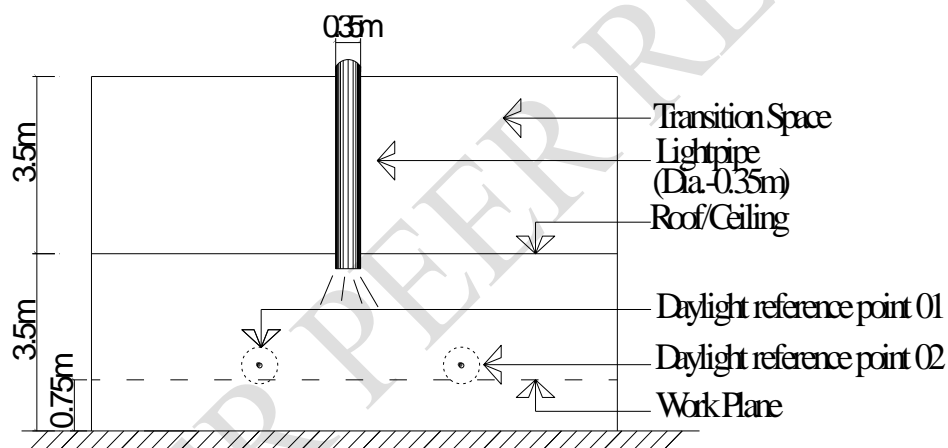


**Figure 9.** Daylighting distribution at central part (f) for case 01(b)

### 3.3 CASE 01(C): PIPE DIAMETER 0.35M

The model was designed to represent an internal open office space with no side wall openings, focusing solely on illumination through a single light pipe. The light pipe was positioned in the center of the room and was directed toward the ceiling. The light was then distributed evenly throughout the room, providing adequate illumination for the occupants. This light pipe, with a diameter of 0.35m, was centrally positioned within the space. A transition space, 3.5m high (equivalent to one floor), was included in the upper part of the model. The dome of the light

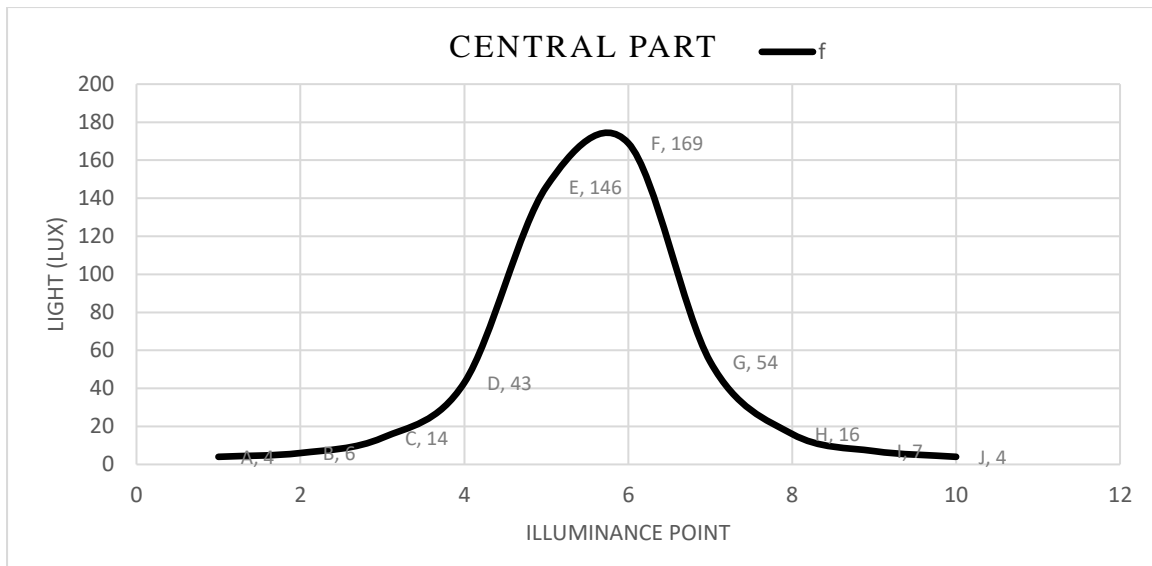
pipe was mounted on the top roof above the transition space, while its diffuser was installed at ceiling level, below the transition space (Fig. 10). Table 4 presents the light levels measured at 100 points across the illuminance plane of Model 01 at 12:00 pm. The light entering the space was transmitted through a ceiling-mounted illumination pipe. As shown in Figure 5.19, daylight illuminated the central region of the space, with illumination levels diminishing significantly toward the periphery. The brightest light level recorded was 169 lux at the center, while the peripheral areas received less than 50 lux, with the minimum light level dropping to just 3 lux. The average illuminance was 20.2 lux, with a standard deviation of 32.3 lux and a median value of 7 lux. The uniformity ratio of the light on the work plane was 0.37, indicating uneven light distribution.



**Figure 10.** Roof plan and section of simulation 01(c)

**Table 4.** Daylighting distribution at illumination plane for case 01(c)

Point	A	B	C	D	E	F	G	H	I	J
a	3	3	3	3	3	3	3	3	3	3
b	4	5	7	10	15	16	11	7	5	4
c	4	5	9	17	31	33	20	10	6	4
d	4	6	11	29	70	77	34	13	6	4
e	4	6	13	41	133	153	51	16	7	4
f	4	6	14	43	146	169	54	16	7	4
g	4	6	12	32	85	95	39	14	7	4
h	4	5	9	20	39	41	23	11	6	4
i	4	5	7	12	18	19	13	8	5	4
j	3	4	5	8	10	10	8	6	4	4

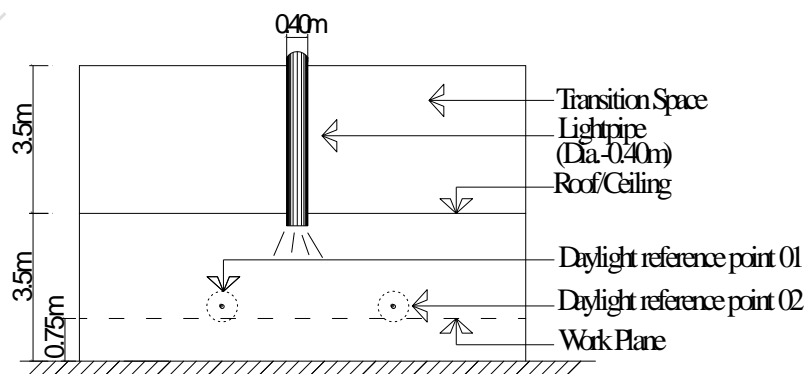


**Figure 11.** Daylighting distribution at central part (f) for case 01(c)

When examining the central part of the space, a curved illuminance distribution was observed, with the highest light levels concentrated at the centre (Fig. 11). The illumination near the edges of the simulated area was notably poor, as the 0.35m diameter light pipe was insufficient to distribute adequate light to the periphery. This highlights the light pipe's limitation in providing uniform lighting across the entire area.

**3.4 CASE 01(D): PIPE DIAMETER 0.40M**

In this simulation study, there was one (1) light pipe which diameter was 0.40m at the centre of the area with a transition space (height 3.5m-one floor) at the upper part of the model. The Dome of light pipe was set at the top roof (top of the transition space) and the ceiling (bottom of the transition space) contained the Diffuser of the light pipe (Fig. 12).

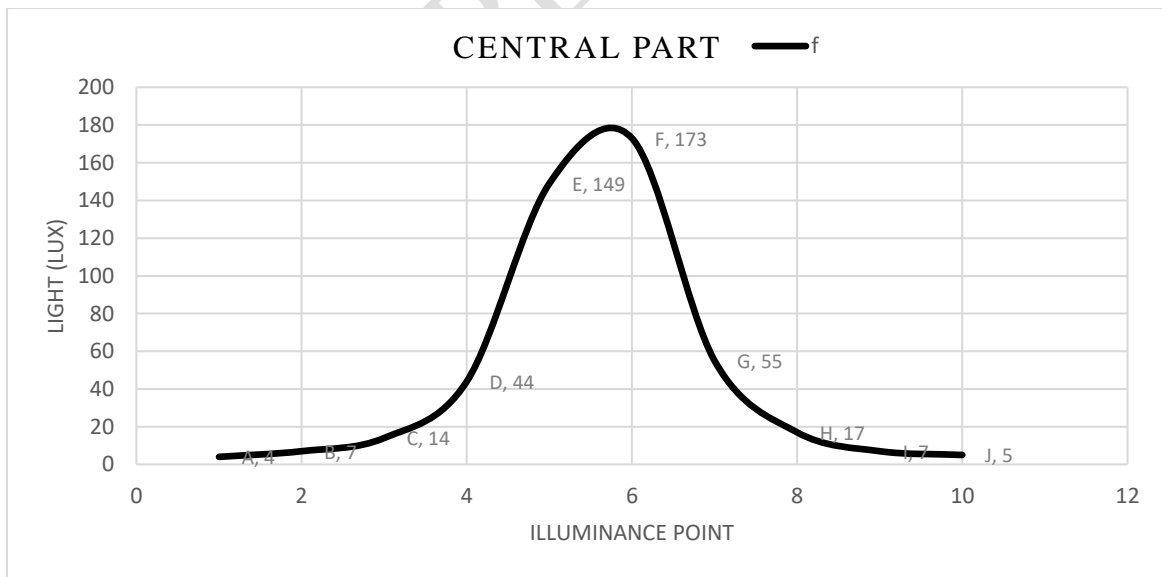


**Figure 12.** Section of simulation model 01(d)

**Table 5.** Daylighting distribution at illumination plane for case 01(d)

Point	A	B	C	D	E	F	G	H	I	J
a	3	3	3	3	3	3	3	3	3	3
b	4	5	7	11	15	16	12	7	5	4
c	4	5	9	18	32	34	20	10	6	4
d	4	6	12	29	71	79	35	13	7	4
e	4	6	14	42	136	156	52	16	7	5
f	4	7	14	44	149	173	55	17	7	5
g	4	6	12	33	87	97	39	14	7	4
h	4	6	10	20	39	42	23	11	6	4
i	4	5	7	12	18	19	13	8	5	4
j	4	4	6	8	10	10	8	6	4	4

Table 5 shows the light level at the 100 points of the illuminance plane of Model 01 at 12.00pm. This light was penetrated by the light pipe installed at the ceiling level. It shows that this daylight only illuminates the centre of the space and constantly decrease at the periphery area. The brightest level of light 173 lux found at the centre of the space and the light found at the periphery area was very low (less than 50 lux). The minimum light was only 3 lux. The average light was 20.6 lux, and the standard deviation was 32.9 lux. The median was 7 lux. The uniformity ratio below the light at work plane was 0.36.



**Figure 13.** Daylighting distribution at central part (f) for case 01(d)

Based solely on the illuminance level at the central part-f, it has drawn a curve line that indicates the highest illuminance level occurs at the center of the space (Fig. 13). As installed

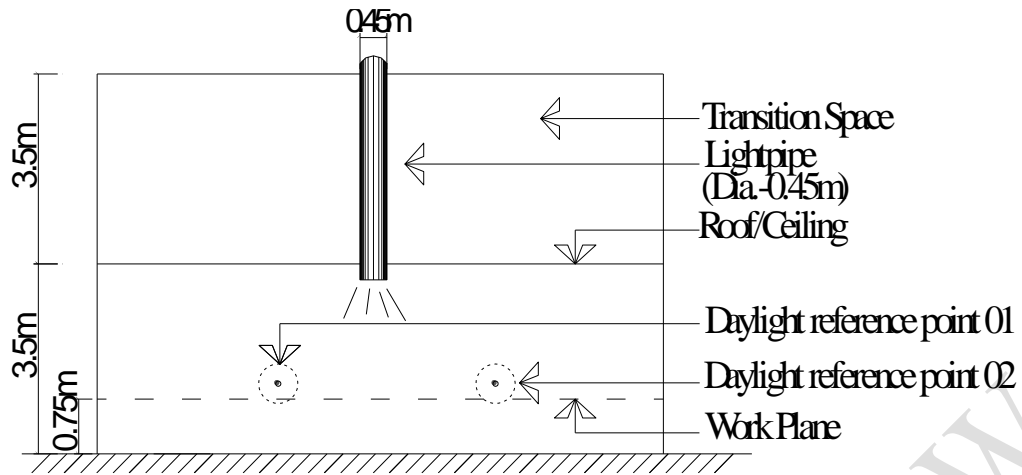
light pipes with 0.40m diameter cannot penetrate more light away from the centre, the lighting near the edge of the simulated area was extremely poor. This poor lighting condition resulted in an uncomfortable environment for the occupants. To improve the lighting, a larger diameter light pipe was needed.

### **3.5 CASE 01(E): PIPE DIAMETER 0.45M**

Besides the internal (open office area) space, this model did not have any openings on the sides. There was one (1) light pipe whose diameter was 0.45m at the centre of the area with a transition space (height of 3.5m, one floor high) at the upper part of the model. The Dome of light pipe was set at the top roof (top of the transition space) and the ceiling (bottom of the transition space) contained the diffuser of the light pipe (Fig. 14).

Study shows the light level at 100 points of the illumination plane of Model 01 at 12.00pm. This light was penetrated by the light pipe installed at ceiling level. Fig. 15 shows that daylight only illuminates the centre of the space and decreases at the periphery. 176 lux was found at the centre of the space, and less than 50 lux was found at the periphery. The minimum light was 3 lux. The average light was 20.9 lux, and the standard deviation was 33.6 lux. The median was 7 lux. The uniformity ratio below the light at work plane was 0.37. The light distribution in the space was non-uniform. The light was brightest at the center of the space and decreased significantly towards the periphery.

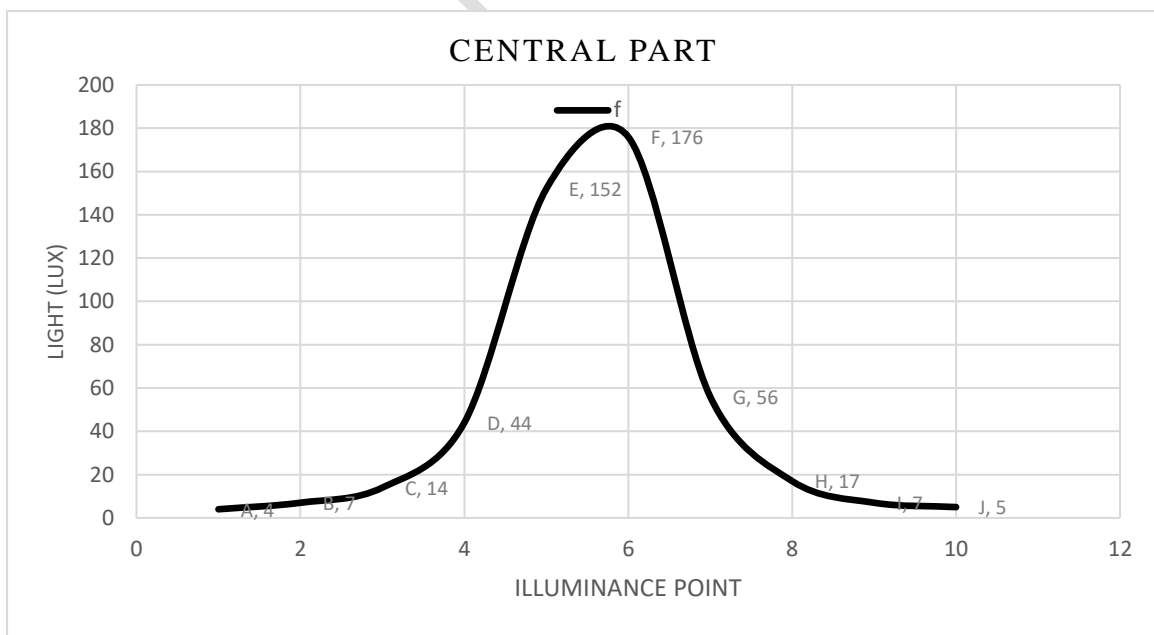
While considering only the illuminance level at the central part-f, it has generated a curve line which indicates that the highest light was found at the centre of the space and the lighting was very poor near the edge of the simulated area as installed light pipe with 0.45m diameter can't penetrate more light away from the centre. The curve line also showed that as the distance from the light pipe increased, the intensity of light decreased. Therefore, we can conclude that the light pipe is not adequate to provide good lighting in a large area.



**Figure 14.** Roof plan and section of simulation model for case 01(e)

**Table 6.** Daylighting distribution at illumination plane for case 01(e)

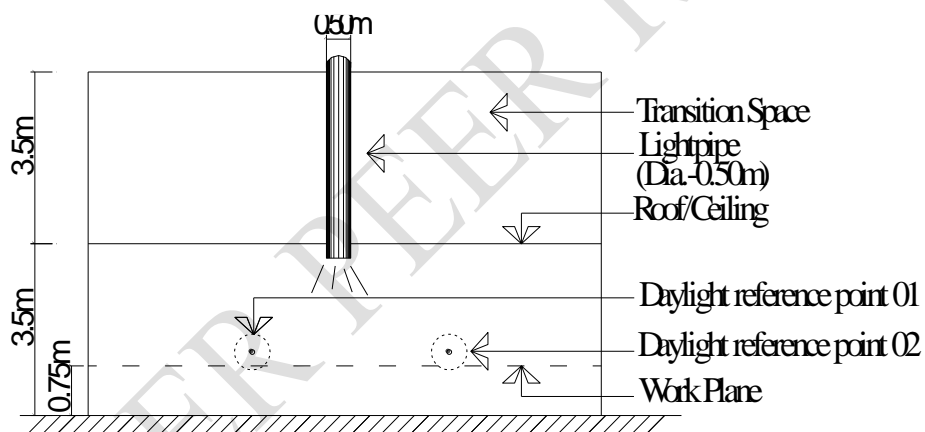
Point	A	B	C	D	E	F	G	H	I	J
a	3	3	3	3	3	3	3	3	3	3
b	4	5	7	11	16	16	12	7	5	4
c	4	5	9	18	33	35	20	10	6	4
d	4	6	12	30	73	80	35	14	7	4
e	4	7	14	42	139	159	53	16	7	5
f	4	7	14	44	152	176	56	17	7	5
g	4	6	12	33	89	99	40	14	7	4
h	4	6	10	21	40	43	24	11	6	4
i	4	5	7	12	19	20	13	8	5	4
j	4	4	6	8	10	10	8	6	5	4



**Figure 15.** Daylighting distribution at central part (f) for case 01(e)

### 3.6 CASE 01(F): PIPE DIAMETER 0.50M

In this stage of simulation, there was one (1) light pipe which diameter was 0.50m at the centre of the area with a transition space at the upper part of the model. The Dome of light pipe was set at the top roof as before and the ceiling contained the diffuser of the light pipe (Fig. 16). It shows the light level at the 100 points of the illuminance plane of Model 01 at 12.00pm. This light was penetrated by the light pipe installed at the ceiling level. Fig. 17 show that this daylight only illuminates the centre of the space and constantly decrease at the periphery area. The brightest level of light 179 lux found at the centre of the space and the light found at the periphery area was very low (less than 50 lux). The minimum light was only 3 lux. The average light was 21.3 lux, and the standard deviation was 34.2 lux. The median was 8 lux. The uniformity ratio below the light at work plane was 0.36.

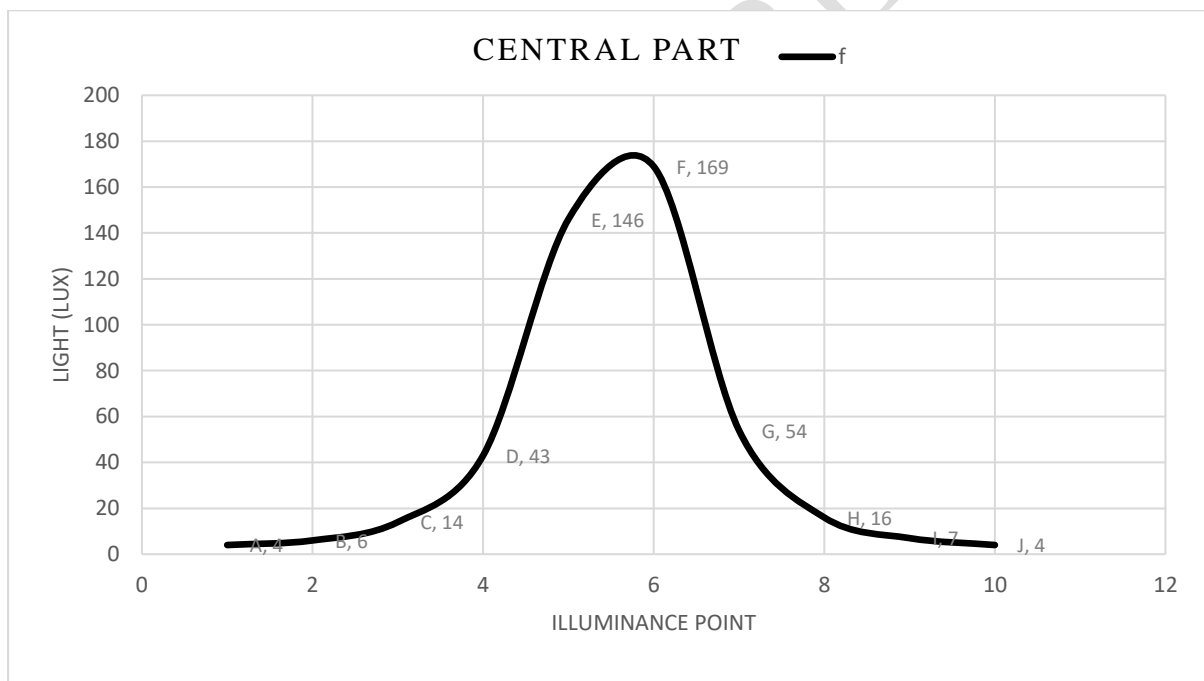


**Figure 16.** Section of simulation model 01(f)

**Table 6.** Daylighting distribution at illumination plane for case 01(f)

Point	A	B	C	D	E	F	G	H	I	J
a	3	3	3	3	3	3	3	3	3	3
b	4	5	7	11	16	17	12	8	5	4
c	4	6	9	18	33	35	21	10	6	4
d	4	6	12	30	74	81	36	14	7	5
e	4	7	14	43	141	162	54	17	7	5
f	4	7	14	45	155	179	57	17	8	5
g	4	6	13	34	90	101	41	15	7	5
h	4	6	10	21	41	44	24	11	6	4
i	4	5	8	13	19	20	14	8	5	4
j	4	4	6	8	10	11	9	6	5	4

By focusing only on the illuminance level at the central part-f, it has generated a curve line that indicates the highest level of light was located at the centre of the space (Fig. 17). This curve line is significant because it provides insights into the distribution of light within the space. Understanding this distribution is crucial for optimizing lighting design and ensuring uniform illumination, which can enhance both the functionality and aesthetic appeal of the environment. It also helps identify areas that may require additional lighting adjustments. As the installed light pipe with a diameter of 0.50m was unable to penetrate more light away from the centre, the lighting near the edge of the simulated area was very poor. This showed that the illuminance level was not evenly distributed. Furthermore, the illuminance level dropped significantly as the distance from the centre increased.



**Figure 17.** Daylighting distribution at central part (f) for case 01(f)

#### 4. COMPARATIVE ANALYSIS

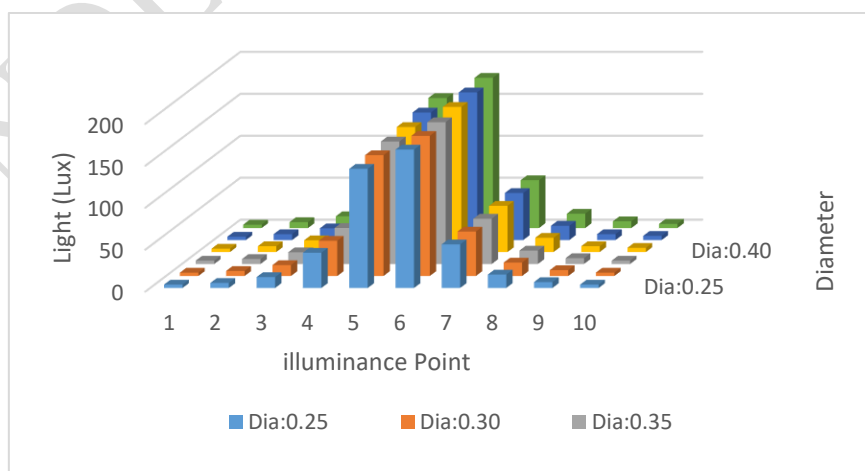
Efficiency of light pipe depends on different variables like light pipe diameter, light pipe length, numbers of light pipe, light pipe positions, window position, material of light pipe etc (Özgün 2007). Diameter of light pipe is an inevitable variable to ensure daylight effectiveness

in deep space office buildings (Song et al., 2023). A larger diameter allows more light to be captured and transmitted, which can enhance the overall illumination levels within a space. However, it also requires more space and might be more costly. On the other hand, a smaller diameter may be more suitable for limited spaces but could result in reduced light output, necessitating careful consideration of the specific lighting needs of the environment. It can also depend on the space volume and layout design of the targeted space. According to Table 7, the lighting level at the center (f) of the illuminance plane is different for every variation for each diameter of light pipes with Model 01 (the deep part of the office floor) for each variation. Using these data, it can be observed that light pipes of different diameters have very little difference in amount of daylight entered. Factors influencing the choice of pipe diameter include the specific lighting requirements of the space, the architectural constraints of the building, and the budget for installation. Additionally, considerations such as maintenance accessibility and the potential for light loss over long distances should also be considered when selecting an appropriate diameter. Daylight entered the office space at the same ratio by the time (hour) and reach at the maximum level at 12.00 PM. After 01.00 PM, it starts to decrease and reach at the minimum level at the end of the office time (06.00 PM) (Fig. 18). The amount of light is as low as only 4 lux at the sensor point A and it gradually slowly increasing up to point D. It reaches its high position at E and F sensor position. The light decreases gradually at the sensor point of G to H and reaches only 4/5 lux. It is also observed that maximum light-165 lux found at F point with the light pipe of 0.25m diameters and 167 lux found at the same point with the light pipe of 0.3m diameters. Similarly maximum light-169 lux found at F point with the light pipe of 0.35m diameters, 173 lux found at the same point with the light pipe of 0.4m diameters and 176 lux found with the light pipe of 0.45m diameters. The maximum light found with the light pipe of 0.50m diameter which was 179 lux at the middle of the room as well as minimum light found with the light pipe of 0.25m diameter. The light pipe of 0.50m

diameter was the most efficient in providing maximum light. The light pipe of 0.25m diameter was the least efficient in providing minimum light. So, it is clear that penetration of light increases with the increasing diameters of light pipe which is located at the center part of the room. Light pipes with larger diameters provide better distribution of light within the room. Therefore, it is important to consider the diameter of the light pipe when designing a room to ensure maximum light penetration. If other variables like light pipe length, number of light pipe, position, light pipe material etc remain unchanged, the light pipe of 0.50m diameter provide maximum amount of light at the simulation space of deep plan office buildings. It also depends on the manufacturing company's engineering and technology. The uniformity ratio below the light at work plane varied from 0.36 to 0.37.

**Table 7.** Daylighting distribution at central part (f) of illumination plane for light pipe of different diameter

Diameter	A	B	C	D	E	F	G	H	I	J
<b>0.25 m</b>	4	6	13	42	142	165	52	16	7	4
<b>0.30 m</b>	4	6	13	42	144	167	53	16	7	4
<b>0.35 m</b>	4	6	14	43	146	169	54	16	7	4
<b>0.40 m</b>	4	7	14	44	149	173	55	17	7	5
<b>0.45 m</b>	4	7	14	44	152	176	56	17	7	5
<b>0.50 m</b>	4	7	14	45	155	179	57	17	8	5



**Figure 18.** Daylighting variation for different diameter of light pipes

## **5. RESEARCH LIMITATIONS**

Despite its insightfulness, this study has some limitations. This study focused on only 10 office buildings in Dhaka, which may not fully represent the diverse architectural and urban context of the city. Regardless of real-world implementation and validation under different environmental conditions, the findings are primarily based on simulations of light pipes of various diameters (Shrestha, 2006). Moreover, daylight measurements focused only on specific hours of the day, without accounting for variations across the day, seasons, or weather conditions. Although highlighting the integration of DGS and HVAC systems as a potential enhancement, practical feasibility and implementation were not examined in depth. Additionally, no detailed economic analysis of the cost-effectiveness of light pipe installations was conducted, leaving scope for further study (Belany et al., 2021).

## **6. CONCLUSIONS**

This study has discussed the objective of the research which was to identify effective configuration of light pipe of the office space to ensure standard illumination levels of daylight at task plane in the context of Dhaka. To achieve the objective, this study has discussed the output of the simulation of different configuration of light pipes to ensure standard illumination levels of natural daylight at task plane. Existing DGS i.e. light pipe system have the potential to provide efficient daylighting within buildings. It was found that the maximum light enters at 12.00 am (2015 Lux) to 01.00 pm (1228 Lux) under the light pipe at working plane by a single straight light pipe. Maximum light found with the light pipe of 0.50m diameter as the penetrated light increases with the increasing diameters of light pipe. However, they do face some challenges that can be summarized as reducing the initial cost and increasing the ease of integration into buildings. Both challenges can be overcome to great extent by the integration of DGS and HVAC systems, which could be achieved through the consideration of many factors such as the design of the duct network layout, the selection of the ducting materials, the

development of the output devices and the development and improvement of many operating aspects.

### **DISCLAIMER (ARTIFICIAL INTELLIGENCE)**

Author(s) hereby declares that NO generative AI technologies such as Large Language Models (ChatGPT, COPILOT, etc) and text-to-image generators have been used during writing or editing of this manuscript.

### **REFERENCES**

- Ander, G. D. (2003). *Daylighting performance and design*. John Wiley & Sons.
- Belany, P., Hrabovsky, P., & Kolkova, Z. (2021). Combination of lighting retrofit and life cycle cost analysis for energy efficiency improvement in buildings. *Energy Reports*, 7, 2470-2483.
- Garcia-Fernandez, B., & Omar, O. (2023). Sustainable performance in public buildings supported by daylighting technology. *Solar Energy*, 264, 112068.
- Lunn, R. M., Blask, D. E., Coogan, A. N., Figueiro, M. G., Gorman, M. R., Hall, J. E., ... & Boyd, W. A. (2017). Health consequences of electric lighting practices in the modern world: a report on the National Toxicology Program's workshop on shift work at night, artificial light at night, and circadian disruption. *Science of the Total Environment*, 607, 1073-1084.
- Nair, M. G., Ramamurthy, K., & Ganesan, A. R. (2014). Classification of indoor daylight enhancement systems. *Lighting Research & Technology*, 46(3), 245-267.
- Özgün, Ö. (2007). Tubular Light Guidance Systems As Advanced Daylighting Strategy. *Istanbul Technical University: Istanbul, Turkey*.

- Paul, S. (2019). Investigation of dual ducting system for daylighting office buildings in Dhaka. M.Arch Thesis, Bangladesh University of Engineering and Technology, Dhaka
- Ramos, G., & Ghisi, E. (2010). Analysis of daylight calculated using the EnergyPlus programme. *Renewable and Sustainable Energy Reviews*, 14(7), 1948-1958.
- Song, J., Dessie, B. B., & Gao, L. (2023). Analysis and comparison of daylighting technologies: Light pipe, optical fiber, and Heliostat. *Sustainability*, 15(14), 11044.
- Shrestha, S. S. (2006). *Empirical validation of building energy simulation software: EnergyPlus*. Iowa State University.
- Wu, Y., Jin, M., Liu, M., & Li, S. (2024). Integrated Systems of Light Pipes in Buildings: A State-of-the-Art Review. *Buildings*, 14(2), 425.
- Baglivo C, Bonomolo M, Congedo PM. Modeling of light pipes for the optimal disposition in buildings. *Energies*. 2019 Nov 13;12(22):4323.
- Mushtaha E, Kana'an BA, Al-Jawazneh RA, Hammad RS. Effect of using different light pipe parameters on the daylight quality in buildings: The case of Jordan. *International Journal of Green Energy*. 2016 Dec 7;13(15):1590-8.
- Wu Y, Jin M, Liu M, Li S. Integrated Systems of Light Pipes in Buildings: A State-of-the-Art Review. *Buildings*. 2024 Feb 4;14(2):425.
- Narayan MB, Joshi J. Modeling of vertical light pipes for daylight illumination of indoor industrial buildings. *Научно-технический вестник информационных технологий, механики и оптики*. 2020;20(6):871-6.