

Design and Development of Hybrid Solar-Wind Energy Storage System for Storage capacity

Abstract— This research paper introduces a hybrid energy storage system using both wind energy and solar energy so that it can remarkably increase the energy storage capacity and the output power of the system. The proposed system is mainly used for storage purposes and the renewable energy sources are used instead of non-renewable energy source. Hybrid systems are considered an efficient research area in energy storage systems owing to their excellent output efficiency and better and excellent charge generation in case of any environmental conditions. It uses the conventional charging controller to charge the battery when wind and extreme solar irradiation conditions occur. The proposed project has started with MATLAB software simulation of the wind storage system and the solar energy storage system. After the Matlab Simulation, the prototype working model has been designed in an efficient manner with all the necessary components in both initial level prototype model and the final level prototype model. Then the working model is developed with the final model design. The results of the generated power from this hybrid energy storage system has been tested and verified by connecting the necessary details.

Index Terms—Hybrid Energy Storage Systems, PV Cell, Wind Turbine, Charge Controller.

I. INTRODUCTION

The concept of storing the electrical energy has been invented and it is the continuous research which is always in progress to find out the better options of storage with minimum costs, maximum energy and longer lifespan. Energy Storage Systems are used for optimized energy management using separate energy and power sources. A single energy storage system cannot have all the advantageous qualities such as production capacity, reduced cost, long lifespan etc. Therefore, hybrid energy storage systems are designed to get the best by integrating highly desirable properties of various energy storage systems. [1].

A solar-wind hybrid power system combines the power of the sun with the power of the wind. It is impossible to supply dependable energy from either solar or wind power alone since the amount of solar radiation and the speed of the wind change throughout the year. The need for a hybrid energy storage system consisting of different types of energy storage options including mainly the renewable energy sources which are integrated and efficient in use, longer storage and longer backup time is very important. Each energy storage system consists of a few basic components including a power generation source i.e. PV cells, windmills, converters, and storage devices.

The idea of using hybrid energy storage systems [1] has been popular from last few decades. An interesting line of work in this regard is [1] that discussed different configurations of hybrid energy storage systems. Furthermore, the paper [2] discussed stand-alone wind power system with several control strategies such as maximum power point tracking (MPPT). Recent works study the integration of renewable wind and solar energy systems with smart grids and micro-grids that include [3], [4], and [5]. An extensive summary of hybrid solar cells with photovoltaic systems is explained in [6]. A more recent review is studied in [7]. To improve the reliability index, the paper in [8] shows an

algorithmic improvement for stand-alone hybrid energy storage system.

Hybrid solar-wind systems can be majorly classified into two basic types which include grid-connected and stand-alone system. In grid-connected systems, the overall backup is provided by the national grid and in stand-alone systems overall system works on its own and fulfil its needs from the solar, wind or storage backups. The hybrid energy storage system would be consisting of different types of options including electrical, chemical, and mechanical sources. These options are ultra-capacitors, lead-acid, lithium-ion batteries, hydrogen fuel cells, flywheel, and other suitable storage options

The primary objective of this research paper is to develop a hybrid energy storage system that consists of renewable power-generating sources with solar and wind with an option to improvise the system in accordance with the latest inventions and researches. The research paper is analyzed the both the solar cell and wind turbine modelling simulation using MATLAB Simulink along with their characteristics. Each portion of the system to designed and modeled on the MATLAB and a thorough analysis will be conducted to analyze the operating characteristics. After modeling and analyzing the working of the system as simulation, a prototype model has been developed to present the practical approach of the hybrid solar and wind energy storage system. The principal configuration of the system will be designed to keep it aligned with the solar power and wind power to generate electrical power and store efficiently.

This research paper has subdivided as in the following sections. Section I discusses about the Introduction about the energy storage systems with brief literature and the need for the hybrid energy storage system. Section II analyzes about the MATLAB simulation of both Solar cell and Wind turbine separately with their characteristics. Section III explains in detail about the design and construction of the prototype model of the hybrid solar and wind energy storage system with its function and operation of working. Section IV

discusses with the results and verification. Section V discusses about the conclusion.

II. SOLAR CELL AND WIND TURBINE MATLAB SIMULATION

A. PV Cell Simulation using Matlab

A Solar cell or Photo Voltaic cell is a semiconductor device which converts light energy to electrical energy by photovoltaic effect. The solar cell is always working in forward biased. In a PV module, many PV cells are connected. A PV array consists of several photo voltaic cells in series and parallel connections. Modelling of PV cells involves the estimation of IV and PV characteristics [9]. The Matlab simulation diagram of solar PV is shown in Fig 1. The Matlab simulation diagram has all necessary blocks to simulate the PV cell and learn about the characteristics of the PV cell in an efficient manner.

One typical PV cell produces less than 2W at 0.5V approximately. The PV cells must be connected in series-parallel configuration on a module to produce enough high power. A PV array is a group of several PV modules, which are electrically connected in series and parallel circuits to generate the required current and voltage.

The Fig.2 shows the output power vs output voltage for the solar cell for a given radiation. In this characteristics graph, the output power is taken in Y-axis and the voltage has taken in X-axis. The peak point of the graph is called MPP (maximum Power Point). In the left region, the cell works like a constant current source, generating voltage to match with the load resistance. In the right region, the current drops rapidly with a small rise in voltage. In this region, the cell works like a constant voltage source with an internal resistance. Somewhere in the middle of the two regions, the curve has a knee point. The important points to be considered in the Fig.2 are the maximum current (short circuit current) at zero voltage and the open circuit voltage (maximum voltage) at zero current. The MPP (Maximum Power Point) produced by the PV array or PV generator is reached at which the product of these two quantities (I_{sc} and V_{oc}).

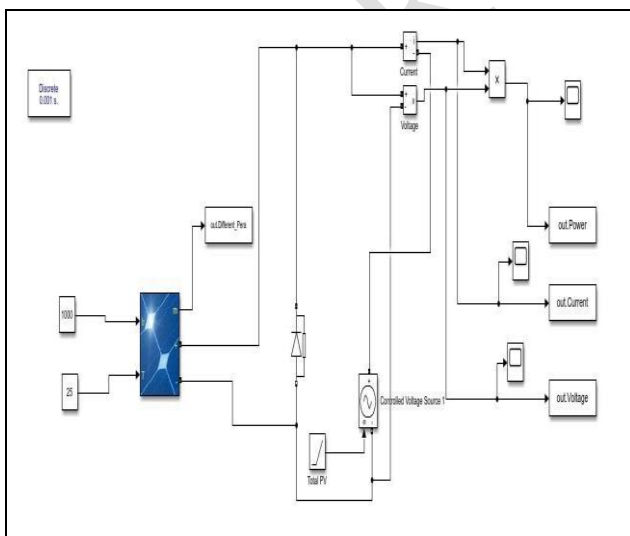

Fig 1.Simulation Model of PV System



Fig. 2.PV Characteristics of a Solar cell

B. Wind Turbine Simulation using Matlab

Wind turbine is used to convert the wind energy to the electrical energy. It consists of rotor of wind blades, generator and a stand called tower and nacelle. Wind turbine has two types as horizontal axis and vertical axis. A wind turbine captures energy from moving air and converts it into electricity. A Matlab Simulink diagram has been designed for the wind turbine as shown in the Fig.3. The system consists of 2 MW active power wind turbine connected to a load of 300 KVA and electric power source of 20KV through the three power transformer. The active power and the reactive power are measured for the different wind speeds and the different blade pitch angle also.

Fig-4 shows the output power of the wind turbine depend on wind speed, so the output power changes when the wind speed is changing. The maximum power for the wind turbine for a particular wind speed is high while for less wind speed the output power decreases. The position of the rotor wind blades are controlled to increase the output power by changing the pitch angle to a certain value so that the fan rotate at higher speed and vice versa [10].

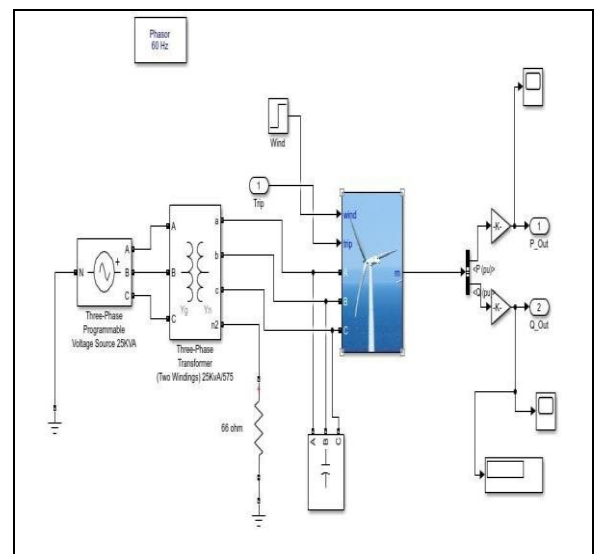

Fig.3.Simulation diagram of Wind turbine

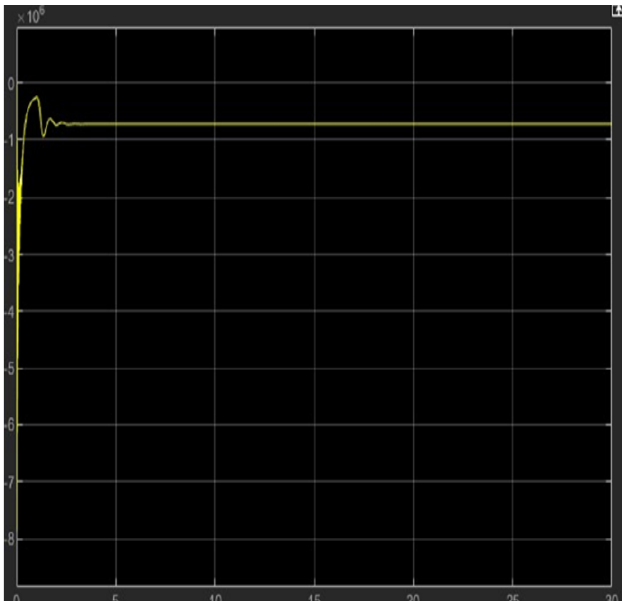

Fig. 4. Wind Turbine power Characteristics from Matlab Simulation

III. DESIGN AND CONSTRUCTION OF THE PROTOTYPE MODEL OF HYBRID SOLAR AND WIND ESS

A Hybrid Energy Storage System based on both solar and wind energy has been designed and proposed for this research paper. This design is a system based approach on the two renewable energy sources. The generation system with Solar Cells or Photo Voltaic cells (PV cells) that will collect the solar energy or light energy and process it using converters and then deliver the power to the connected load. The extra amount of energy obtained from the solar cells would be transferred to the battery that is connected via the MPPT system. The MPPT system is employed to regulate the power of solar cells and deposit it into the battery [11]. The second power can be generated through a windmill unit as well that works by utilizing wind energy. Windmill is beneficial since it can work round the clock. However, it primarily depends upon the wind power and hence can be an inconsistent source of power generation. Usually, it is preferred that the electrical generation sources are renewable and can support the system for maximum available time, with only minimal capital investment [12].

The solar panel provides energy in day light or high light irradiation condition. Windmill is beneficial since it can work round the clock. The wind power can be an inconsistent source of power generation at the time of low wind condition. However, in night and evening time, the wind condition is relatively better than daytime, which make solar and wind-mill hybrid system and efficient system to be used to enhance energy generation.

The wind power plant is well fabricated using 3D printing with wind blades and the solar panel has been taken from the Higher Colleges of Technology Electrical engineering department laboratory store. Most of the other necessary components are also taken from the laboratory store.

The proposed prototype system consists of a solar panel, windmill and a hybrid combination of these two energy resources to obtain a high efficiency energy storage system. The system is designed using the hardware equipment which is low in cost but give high output efficiency. Similarly, the operational limitation of the work can also be analyzed which will give this work more privilege over simulated work.

The proposed design consists of solar panel, windmill, servo motor, solar charge controller, two full bridge rectifier and battery. The project is designed as following:

1. A two number of 12 V/150 Watts solar panels.
2. A windmill is designed using the 3D printer to print the parts one by one and then put them together. When the windmill was complete, it was connected to a rod using bearings and attached the rod to a servo motor to test the amount of wind energy which we can get. This wind mill is designed to generate power around 600 watts.
3. The stand of the solar panels and the solar - windmill is designed all together and started testing the amount of voltage which is produced.
4. The wires of the motor are separated to measure the voltage of the 2 separate phases.
5. To get DC and be able to connect the phases in series so that the voltage is increased and the two full bridge rectifier circuits is constructed and connected both DC outputs of each part in series.
6. The solar panels is connected to one charging controller and the windmill output to another charging controller, then the battery will be connected in parallel to both controllers so that the power from both sources will be charged in the same battery.

The proposed prototype design is shown in Fig.5 which explains the working principle of the hybrid solar and wind energy storage system. This is the model which replica the prototype of this research project.

This model consists of the following main components. Solar panel, Wind turbine, Charge Controller, Battery, Inverter and the Distribution Box to connect the loads. The output from the solar panel and the output from the wind turbine are connected to the hybrid charge controller. The output from the charge controller has been inputted to the battery for the storage and then this battery output is going to the inverter. The inverter which converts DC to AC and gives input to the AC power distribution box if the loads are only AC loads. If the DC loads are also included, then the supply voltage has been directly taken the storage battery.

Here the charge controller receives both the different energies say solar panel and wind turbine. These two energies are working independently. But it should control the charging of the battery in an optimum manner as well defined characteristics.

Hence connector/disconnector switch is used to select which energy is used to input to the charge controller among the two energy sources based on time and weather.

Above concept of design has been given to the students to start the research project. Initially this research idea has been given to the students and under the supervision of the Project Supervisor, the students develop a first prototype model as initial level prototype model. This model is shown in the Fig.6. The initial prototype model is just a demo model shown to the second year electrical engineering students of the course Power Generation and transmission.

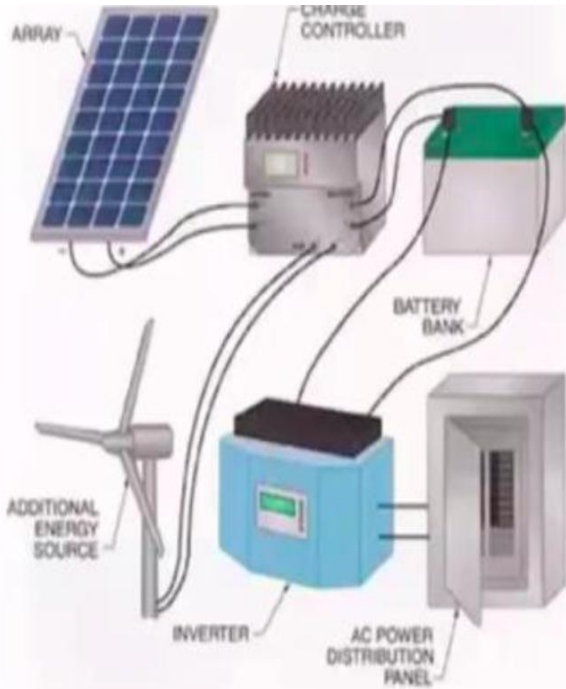

Fig.5. Model diagram for the prototype design

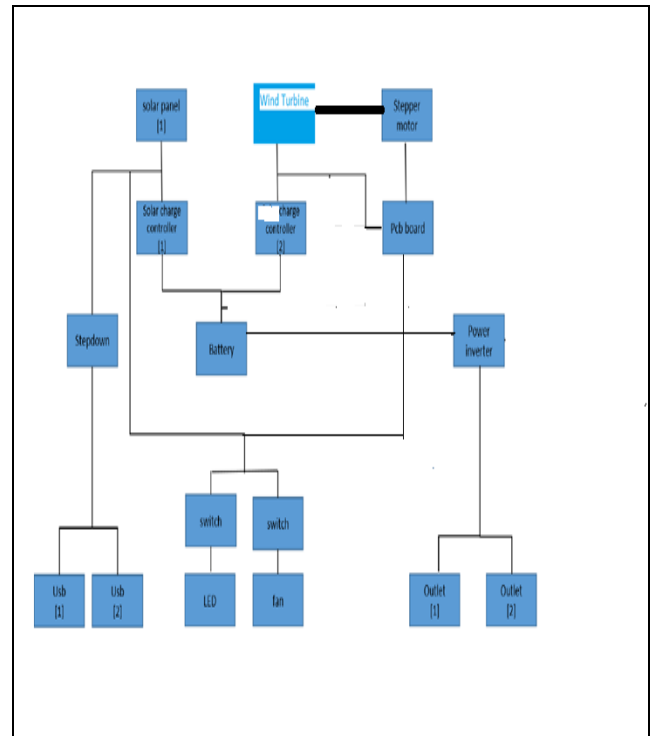

Fig.7. Block diagram for the design of final prototype model

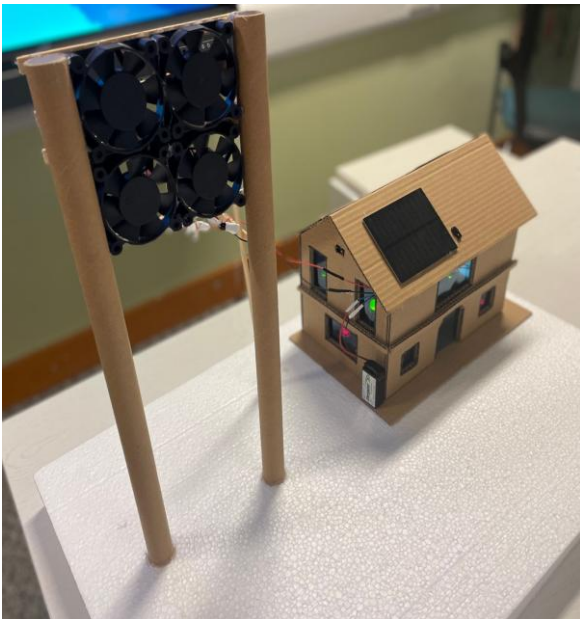

Fig.6. Initial level prototype Model

The following block diagram shown in Fig.7 explains in detail manner about the complete design of the final level of prototype model of our research topic hybrid solar and wind energy storage system. There are six outputs has been taken in this research project. They are two USBs, one LED, one fan and two output points to connect the AC loads. There are two charge controllers are used out of which one is for the solar energy and the other one is for the wind energy. The power inverter is used to convert the battery DC power to AC power and used for the AC loads connection. The loads USB 1 and USB 2 are connected from the stepdown output of solar panel. The loads LED and fan are connected directly from the output of the solar panel. The PCB board consists of full wave bridge rectifiers to rectify the AC output from the wind turbine to the DC output.

The rotor blades are fabricated with 3D printer and the stand is connected to the servo motor to this assembly of wind blades as vertical axis blades. A multi-meter is connected to this setup to get the output voltage. The two-phase output of the windmill is then connected to the bridge circuits. The bridge circuits converted the positive and negative AC signal to the DC signal to make it compatible with the hybrid solar system. After connecting the windmill and testing it to make sure that it is working and that there is enough voltage that is being produced, the solar panels are added as placing them on the top of the stand and then connecting them together to get the added power and connect it with the solar charge controller.

Then the wind output from the PCB that we designed with the full bridge rectifier with the other solar charge controller and then connected the battery with them. It is necessary to add a switch to enable controlling the battery usage and turning the system on only when needed to avoid extra losses, and then a DC connector is added to the battery so that it can be recharged it in case the loads used up all the power that there was a need for charging the battery quickly, rather than waiting for the solar or the wind source to charge the battery (these two components say switch and DC connector are not shown in the Fig.7). Then a front panel for the stand is designed to fix the switch and the connector as well as the other parts of the load ports including the DC and the AC loads ports. After connecting the front panel on the top of the prototype model, the loads are connected. Then the inverter and other components are connected. At the end, the 12V loads of which a light bulb and a fan are connected. For each one of these loads, a switch is placed so that turning on the loads is controlled by switch as on and off whenever needed. All the components are connected in an efficient manner and the final prototype model is arranged as a complete one as shown in Fig.8.



Fig.8. Developed Final Level prototype Model

This prototype model has been connected to online mode as well as offline mode. Online mode demonstrates the connection of the developed final prototype model to the Smart grid. But in this project, the online mode connection is not proceeded. Offline mode connection makes the connection of the developed prototype model to the AC Distribution Box and the DC distribution box. The DC and AC loads are connected via the respective distribution boxes.

IV. RESULTS AND VERIFICATION

The output from the windmill is approximately 5.5V AC from each positive and negative cycle of the AC output from wind-mill. The output is taken from multi-meter. The 5.5V AC is under the mild wind conditions.

Under high wind and light conditions the expected output will be as follows:

1. High wind will increase the output of the windmill
 2. More the light, more will be the electrical energy generated.
- We have tested the system to make sure that all the parts are working as required, after making sure that the wind source is providing the needed voltage It has to be tested the loads including the AC and the DC loads both 12V and 5V loads.

The initial level prototype model as a demo model has measured the power of 7.4 V and each of 1.85 V. The solar panel which has 1.7V. Finally the resultant voltage of the battery produced was 9V as shown in the multimeter.

The final prototype model has shown the power produces as follows:

The maximum capacity can be produced for the wind power plant that is ± 100 W and for solar power plants, the maximum capacity can be produced is ± 80 W. The maximum power can be produced by the hybrid power plant is a 200W for the combination of wind power plants and solar power plants This prototype model can be tested well with the 6 loads as already mentioned. The two AC loads are connected through the two output ports. The other loads are checked by connecting the bulb, fan, charging the two USBs.

V. CONCLUSION

This research project analyzed the Matlab Simulation of both solar and wind power source separately in an effective manner with their power characteristics. The wind speed and solar irradiation are estimated to find the feasibility and with

the availability of the energies, then the model has been proposed. The Matlab Simulation results show that solar radiation and temperature influences the output of the system mentioned. Combining the two renewable sources as solar energy and wind energy for generation of electricity to meet the demands gives a clean energy output. After generation, the produced energy is stored for future purpose in the battery.

The design and the execution of this hybrid system has been worked successfully which combines both the solar and the wind energy to increase the efficiency of the solar panels and wind turbine to get a better outcome to make these renewable systems more reliable and effective. The developed prototype system was capable of powering different types of loads including AC and DC loads of different voltages, the tests had done on this system proved that it is very effective and that it can be used as a power source to run the different types of the electric devices by just using renewable energy, but from two sources rather than the traditional single source.

The future scope of this research project is to overcome the power quality issues. This research project is very efficient for the production of clean energy from the renewable energy sources but power quality issues effects the performance of the overall systems. Power quality problems includes voltage sag,, harmonics and power transients which is mainly reduce the quality of power generation from the solar and wind energy. The usage of more power electronic devices also has an impact of the energy output leading to fluctuations. To overcome the power quality issues, it is recommended to use some techniques like implementing static compensators. Advanced methods need to be used to record the solar and wind data so that an estimation of power can be calculated for a continuous energy supply. The future scope of this research project has been first tested with MATLAB Simulation and then the real world power quality issues will be simulated in the designed Simulation model.

REFERENCES

- [1] T. Bocklisch, "Hybrid energy storage systems for renewable energy applications," *Energy Procedia*, vol. 73, no. 2015, pp. 103–111, 2015.
- [2] T.-L. Pan, H.-S. Wan, and Z.-C. Ji, "Stand-alone wind power system with battery/supercapacitor hybrid energy storage," *International Journal of Sustainable Engineering*, vol. 7, no. 2, pp. 103–110, 2014.
- [3] Y. Zhang, Y. Xu, H. Guo, X. Zhang, C. Guo, and H. Chen, "A hybrid energy storage system with optimized operating strategy for mitigating wind power fluctuations," *Renewable Energy*, vol. 125, pp. 121–132, 2018.
- [4] S. Tamalouzt, T. Rekioua, D. Rekioua, and F. Hamoudi, "Variable speed wind generator associated with hybrid energy storage system-application for micro-grids," in *2017 International Renewable and Sustainable Energy Conference (IRSEC)*. IEEE, 2017, pp. 1–6.
- [5] R. Zhu, A.-I. Zhao, G.-c. Wang, X. Xia, and Y. Yang, "An energy storage performance improvement model for grid-connected wind-solar hybrid energy storage system," *Computational Intelligence and Neuroscience*, vol. 2020, 2020.
- [6] R. A. Badwawi, M. Abusara, and T. Mallick, "A review of hybrid solar pv and wind energy system," *Smart Science*, vol. 3, no. 3, pp. 127–138, 2015.
- [7] M. Al-Ktranee and P. Bencs, "Overview of the hybrid solar system," *Review of Faculty of Engineering Analecta Technica*, no. 14, pp. 100–108, 2020.

- [8] S. Moghaddam, M. Bigdeli, M. Moradlou, and P. Siano, "Designing of stand-alone hybrid pv/wind/battery system using improved crow search algorithm considering reliability index," *International Journal of Energy and Environmental Engineering*, vol. 10, no. 4, pp. 429–449, 2019.
- [9] Kamal Keshavani, Jigar Joshi, Vishrut Trivedi, Mitesh Bhavsar, "Modelling and Simulation of Photovoltaic Array Using Matlab / Simulink", *IJEDR*, Volume 2, Issue 4, ISSN:2321-9939.
- [10] Roshen T. Ahmed, Mahdi A.Abdul-Hussain , " Modelling and Simulation of Wind Turbine Generator Using Matlab –Simulink , *Journal of Rafidian University College* , PP 282-299, Issue No.40/2017, ISSN (1681-6870).
- [11] P. Arul, V. K. Ramachandaramurthy, and R. Rajkumar, "Control strategies for a hybrid renewable energy system: A review," *Renewable and sustainable energy reviews*, vol. 42, pp. 597–608, 2015.
- [12] T. Burton, D. Shape, N. Jenkins, E. Bossany, "Wind Energy Handbook", J. Wiley & Sons, Ltd. 2001